



ASPIRATORE WX15

Il silo di carico modello WX15 ideale per dosare i prodotti granulari in modo da automatizzare il vostro impianto con la minima spesa e manutenzione.

- ⇒ IDEALE PER ALIMENTARE STUFE E CALDAIE A BIOMASSA
- ⇒ FUNZIONAMENTO AUTOMATICO
- ⇒ ADATTABILE A QUALSIASI IMPIANTO
- ⇒ FASCIA ORARIA PROGRAMMABILE

Dotazioni di serie

- ◇ Pannello comandi con display lcd retro-illuminato
- ◇ Filtro a cartuccia in poliestere
- ◇ Sensore di livello
- ◇ Valvola di scarico prodotto
- ◇ Cavo di alimentazione shuko da 3 mt



MODELLO	Unità di misura	WX15
Potenza elettrica nominale	W	1500
Tensione nominale	V	230
Frequenza nominale	Hz	50
Capienza tramoggia interna	lt	7
Depressione max	Mbar	220
Tipo di filtro	/	Cartuccia autopulente
Alimentazione sistema pulizia	Aria	8 bar
Struttura ed involucro	Materiale	Acciaio al carbonio
Peso totale	kg	24
Ingombro	mm	330 x H700
Tubi IN/OUT Ø	mm	Ø 50

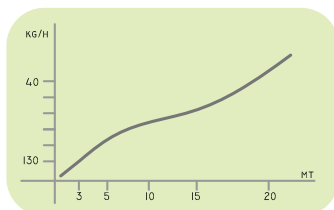
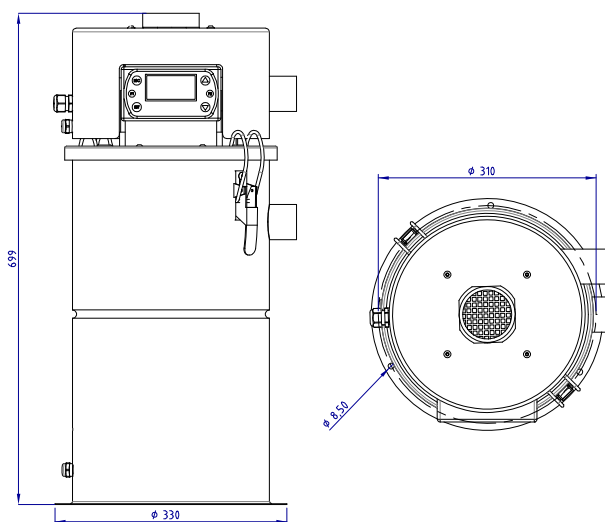

Accessori

